



CST5022A MASK-type Speech IC

1. CST5022A General Descriptions

CST5022A series are 4-bits micro-controller which could play 4 channel melody or 4 channel ADPCM with PWM direct drive circuit. PWM resolution is 8/10/12 bits. They include a low cost, high performance CMOS micro-processor. The clock frequency of this up is typically 8.192 ($\pm 3\%$) MHz. This chip operates over a wide voltage range of 2.0V~5.5V. It contains program ROM (PROM) and data ROM (DROM) inside. The maximum program ROM is 4K words and maximum data ROM size is 66K byte. The maximum working SRAM is (128+2) nibbles. It is provided with total 16 software programmable I/O Ports.

2. CST5022A Features

- Operating voltage: **2.0V to 5.5V**
- MCU Operation frequency: **8.192MHz**
- Memory Size
 - Program ROM size: **4K*12-bits MASK type**
 - Data ROM size: **Maximum 66K*8-bits MASK type**
 - SRAM size: **128*4 bits**
 - User register: **2*4 bits**
- Wakeup function for power-down mode:
- HALT mode wakeup source: Port A, Port B, Port D and Port E/CE can wake-up from HALT mode to NORMAL mode and executing wake-up sub-routine program.
- RTC wakeup: Clock source comes from internal LRCOSC, time period 1/16/64/128 ms.
 - ※RTC wakeup function only support in CST5041S1.
- 12 input/output pins: Port A, Port B and Port D can be defined as input or output port bit by bit.
- 4 input/output ports or 4 input only ports or 4 output only ports "Port CE/E/C" defined by option:
 - If input only ports are employed, Port E defined as input only ports.
 - If output only ports are employed, Port C defined as output only ports.
 - If input/output ports are selected, Port CE defined as input/output ports bit by bit.
- Four reset condition:
 - Low voltage reset. (LVR = 2.0V)
 - Power on reset.
 - External reset pin. (active low)
 - Watch dog timer overflow.
- One internal interrupt sources:
 - PWM interrupt.
- WDT
 - Watch dog timer, can enabled/disabled by option.
 - WDT period is 256*256*16/Fsys. (WDT period is 0.13 sec for system clock=8.192MHz)
- Audio output:
 - Support PWM or DAC mode by option.
 - Support 8/10/12 bits.
- Support option set for pull down resistor 1M, 50K or 220K Ohm, reset pin (PB3 or PC3), low voltage reset...etc.
- Oscillator fuse option **$\pm 3\%$, temperature & voltage compensation.**
- Support **security option (1 bit)** for read inhibition.
- Support 16-levels LVD function.



CST5022A MASK-type Speech IC

3. CST5022A Packaging and Pads Information

3.1 Pads

PAD Name	Type	After Reset	Description
Reset, Power Input			
VCC	P	High	Power input of I/O port.
VSS	P	Low	Ground input except PWM block power. It could be double bonded with VPS pad.
VPD	P	High	PWM block power input in normal operation.
VPS	P	Low	The ground pad of PWM block. It could be double bonded with VSS pad.
General I/O ports			
PA3~PA0	I/O	zzzz	Port A is a programmable input/output port.
PB3~PB0	I/O	zzzz	Port B is a programmable input/output port. PB3 can be employed as reset pin according to the option.
PD3~PD0	I/O	zzzz	Port D is a programmable input/output port. (Only supported for CST5041S1)
PE3~PE0	I	zzzz	Port E is an input only port defined by option.
PC3~PC0	O	0000	Port C is an output only port defined by option, PC3 can be employed as reset pin according to the option.
PCE3~PCE0	I/O	zzzz	Port CE is a programmable input/output port defined by option, PCE3 can be employed as reset pin according to the option.
PWMP	O	Low	Audio output PWM(+).
PWMN	O	Low	Audio output PWM(-).

Table 1: Pad Description



CST5022A MASK-type Speech IC

3.2 Package

CST5022 provides SOP8, SOP16, SSOP24

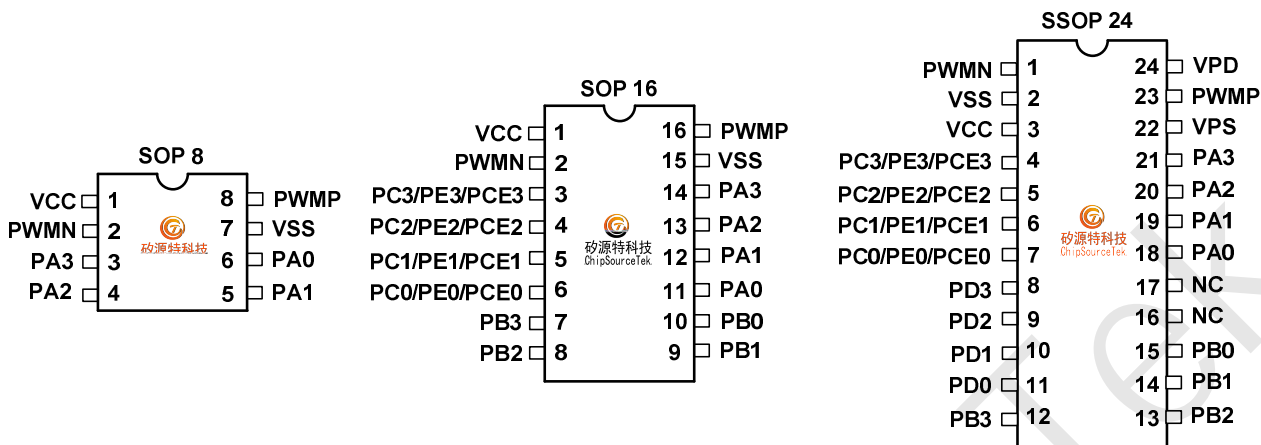

3.2.1 SOP8





CST5022A MASK-type Speech IC

3.2.2 SOP16

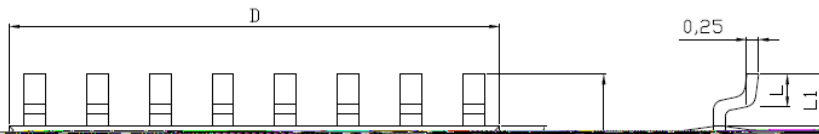

Symbol	Dimensions In Millimeters	
	Min	Max
A		1.75
* A1	0.10	0.25
A2	1.40	1.50

3.2.3 SSOP24



Symbol	Dimensions In Millimeters	
	Min	Max
A		1.75
* A1	0.10	0.25
A2	1.40	1.50



CST5022A MASK-type Speech IC

3.3 Block Diagram

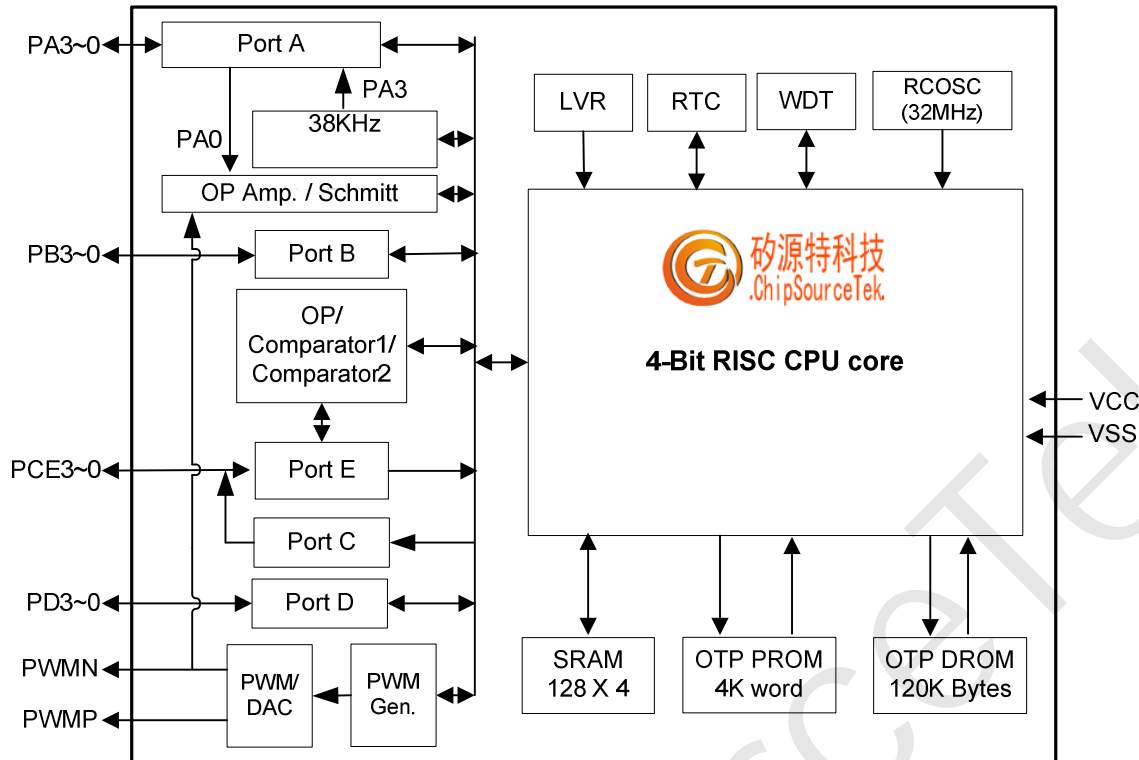

Figure 1. Block diagram

4. CST5022A ELECTRICAL CHARACTERISTICS

4.1 Absolute Maximum Ratings

Parameters	Symbol	Value	Unit
DC Supply Voltage	Vcc	-0.5 to 6.0	V
Input Voltage	Vin	-0.5 to Vcc+0.5	V
Operating Temperature Range	Ta	0 to +75	°C
Storage Temperature Range	Tstg	-25 to +85	°C

Table 2: Absolute Maximum Ratings

4.2 AC Characteristics

VCC=3.0V, Ta=25°C unless otherwise noted.

Parameters	Symbol	Minimum	Typical	Maximum
Operating Frequency(RC Oscillator)	Fsys	7.946MHz	8.192 MHz	8.43MHz
RC reset time-constant	Trrc	-	10 us	-
Data ROM data ready time	Tdrr	-	-	2/Fsys

Table 3: AC Characteristics

4.3 DC Characteristics

VCC=3.0V, Ta=25°C unless otherwise noted.

Parameters	Symbol	Minimum	Typical	Maximum	Condition
Power supply range	Vcc	2.0 V	-	5.5 V	
Supply current	Iop		5mA		System clock 8.192MHz PWM disabled
Stand-by Current	I _{STBY}		3uA		VCC=5.0V, MCU halt System clock off
Input high voltage	Vih		0.55 VCC		
Input low voltage	Vil		0.55 VCC		
Input leakage current	I _{lk}		0.1 uA		
Output high voltage	Voh	0.95 VCC			no load
Output low voltage	Vol			0.05 V	no load
Output high current in high source capacity mode	Ioh0		20mA		Vout=2.0 all ports High source capacity
Output low current in high sink capacity mode	Iol0		20mA		Vout=1.0 all ports High sink capacity
Output high current in normal source capacity mode	Ioh1		4mA		Vout=2.0 all ports Normal source capacity
PWM output load		-		8 ohm	Speaker impedance
Pull up resistor of PB3, PC3	Rrst	-	50K Ohm	-	Pins with pull up PB3 or PC3 reset pins Vin=0V
Pull-down resistance	Rpd1	-	50K Ohm	-	Pins with pull-down PA, PB and PE



CST5022A MASK-type Speech IC

PROM address	Function description
0x000 ~ 0x001	Reset
0x004 ~ 0x005	Wake-up
0x008 ~ 0x009	Interrupt
0x00A ~ 0xEFF	User code
0xF00 ~ 0xFFF	Reserve area

Table 3: Memory Map of PROM

5.2 Data ROM (DROM)

The DROM is a MASK type memory. The maximum **DROM is 66K*8-bits** which stores the 8-bits wide data for ADPCM or melody data ...etc. The last 64 location is a reserved area. The user shall not use this area in any case. Assembler shall check user data ROM on this limit. Hardware does not need to check this restriction.

DROM address (DMA)	Function description
0x00000 ~ 0x000FF	User area
0x00100 ~ 0x001FF	User area
0x00200 ~ 0x002FF	User area
...	...
0x107B0 ~ 0x107BF	User area (Max. size of CST5022A)
0x107C0 ~ 0x107FF	System area, last 64 location (don't use it)

Table 4: Memory Map of DROM

DROM is addressed by five registers DMA4, DMA3, DMA2, DMA1 and DMA0. After these registers are specified by software, the data need enough delay time, T_{drr} in the table of "AC Characteristics". After this delay time, the data can be read from data register (DMDL & DMDH).

Ex:

```
LD    (DMA0), A
...
LD    (DMA4), A    ; Set DMA0~4
LD    A, (DMDL)   ; Read low nibble data from DROM, address as DMA4~0.
LD    A, (DMDH)   ; Read high nibble data from DROM, address as DMA4~0.
```

Symbol	Addr	R/W type	Reset	D3	D2	D1	D0	Description
DMA0	18H	R/W	xxxx	DMA0.3	DMA0.2	DMA0.1	DMA0.0	DMA0~4, five register built a 20-bits addressing space for read DROM 8-bits data. DMA0 is lowest nibble, DMA4 is highest nibble of DROM address.
DMA1	19H	R/W	xxxx	DMA1.3	DMA1.2	DMA1.1	DMA1.0	
DMA2	1AH	R/W	xxxx	DMA2.3	DMA2.2	DMA2.1	DMA2.0	
DMA3	1BH	R/W	xxxx	DMA3.3	DMA3.2	DMA3.1	DMA3.0	
DMDL	1CH	R/W	xxxx	DMDL.3	DMDL.2	DMDL.1	DMDL.0	Low nibble of DROM data read from this address.
DMDH	1DH	R/W	xxxx	DMDH.3	DMDH.2	DMDH.1	DMDH.0	High nibble of DROM data read from this address. Write this register means reset watch dog timer if this timer is enabled by option.
DMA4	1EH	R/W	xxxx	-	-	-	DMA4.0	DMA4 is highest nibble of DROM address

Table 5: SFRs about DROM

CST5022A MASK-type Speech IC

PWM_CTRL	09H	R/W	--x0	reserved	reserved	ENINT	ENPWM	ENPWM: "1" Enable PWM, "0" Disable PWM. ENINT: Enable global interrupt.																				
AUD_DL	0AH	W	xxxx	AUD_DL3	AUD_DL2	AUD_DL1	AUD_DL0	AUD_DL[3:0]: The low nibble of 8-bits PWM. The bit5~2 of 10-bits PWM. The bit7~4 of 12-bits PWM.																				
AUD_DH	0BH	W	xxxx	AUD_DH3	AUD_DH2	AUD_DH1	AUD_DH0	AUD_DH[3:0]: The high nibble of 8 bits PWM. The bit9~6 of 10 bits PWM. The bit11~8 of 12 bits PWM. Note: AUD_DH3 is sign bit, "0" means positive.																				
Reserved	0CH~0DH	-	xxxx	-	-	-	-	Reserved																				
DATA_PE	0EH	R/W	xxxx	DPE3	DPE2	DPE1	DPE0	Port E defined as I/O port or input port depends on option PEIO. Read from Port E input port and write to output port.																				
USER2	0FH	R/W	xxxx	USER2.3	USER2.2	USER2.1	USER2.0	General purpose user register.																				
IADJ	10H	R/W	0000	CMPSEL1	CMPSEL0	ADJ1	ADJ0	CMPSEL[1:0]: Enable option PCEIO, ENOP, ENCMP1, and set ENGAIN=1, Select Gain in record mode. <table border="1" style="margin-left: 20px;"> <thead> <tr> <th>CMPSEL[1:0]</th> <th>GAIN</th> </tr> </thead> <tbody> <tr> <td>00</td> <td>50</td> </tr> <tr> <td>01</td> <td>100</td> </tr> <tr> <td>10</td> <td>150</td> </tr> <tr> <td>11</td> <td>200</td> </tr> </tbody> </table> ADJ[1:0]: Adjust the frequency, when enable option OTPADJ. <table border="1" style="margin-left: 20px;"> <thead> <tr> <th>ADJ[1:0]</th> <th>Frequency %</th> </tr> </thead> <tbody> <tr> <td>00</td> <td>-4%</td> </tr> <tr> <td>01</td> <td>-2%</td> </tr> <tr> <td>10</td> <td>2%</td> </tr> <tr> <td>11</td> <td>4%</td> </tr> </tbody> </table>	CMPSEL[1:0]	GAIN	00	50	01	100	10	150	11	200	ADJ[1:0]	Frequency %	00	-4%	01	-2%	10	2%	11	4%
CMPSEL[1:0]	GAIN																											
00	50																											
01	100																											
10	150																											
11	200																											
ADJ[1:0]	Frequency %																											
00	-4%																											
01	-2%																											
10	2%																											
11	4%																											
CNTI	11H	R/W	0000	ENGAIN	-	S2S	-	ENGAIN: 1: Open Built-in gain in record mode. 0: Close Built-in gain in record mode. S2S: PWM input Data format 1: 2's format 0: sign																				
PWMWK	12H	R/W	0000	PWMWCFG	CLAPSEL1	CLAPSEL0	PWMWKEN	PWMWCFG : When wakeup source form Speaker, it will be set by hardware, it could be clear by software. PMMWKEN: Wakeup by speaker. 1: Enable PWM wakeup function. 0: Disable PWM wakeup function. CLAPSEL[1:0]: Sensitivity of speaker wakeup. <table border="1" style="margin-left: 20px;"> <thead> <tr> <th>CLAPSEL[1:0]</th> <th>Sensitivity</th> </tr> </thead> <tbody> <tr> <td>00</td> <td>Level 1 (High)</td> </tr> <tr> <td>01</td> <td>Level 2</td> </tr> <tr> <td>10</td> <td>Level 3</td> </tr> <tr> <td>11</td> <td>Level 4 (low)</td> </tr> </tbody> </table>	CLAPSEL[1:0]	Sensitivity	00	Level 1 (High)	01	Level 2	10	Level 3	11	Level 4 (low)										
CLAPSEL[1:0]	Sensitivity																											
00	Level 1 (High)																											
01	Level 2																											
10	Level 3																											
11	Level 4 (low)																											
LVD_CTRL	13H	R/W	0000	-	-	LVD_FLAG (R)	LVDEN	LVD_FLAG: (Read only) The flag of LVD, '1'=LVD sensing. LVDEN: '1'=Enable LVD function, '0'=Disable LVD function.																				



CST5022A MASK-type Speech IC

LVDS	14H	R/W	0000	LVDS3	LVDS2	LVDS1	LVDS0	LVDS[3:0]: LVD level selected, 1111=3.8V, 1110=3.7V, 1101=3.6V, 1100=3.4V, 1011=3.3V, 1010=3.2V, 1001=3.1V, 1000=3.0V, 0111=2.9V, 0110=2.8V, 0101=2.7V, 0100=2.5V, 0011=2.4V, 0010=2.3V, 0001=2.2V, 0000=2.1V.
Reserved	15H	-	xxxx	-	-	-	-	Reserved
RTC	16H	R/W	0000	RTCFCG	RTCEN	RTCS1	RTCS0	In HALT mode, RTC can wake up MCU and program will go to wake up vector (\$004h). RTCFCG: RTC overflow flag. 0: RTC overflow not occurred. 1: RTC overflow occurred, it can be cleared by software. RTCEN, RTC function enable/disable, '1'=Enable, '0'=Disable. RTCS[1:0], RTC period select. [1,1]: 128ms, [1,0]:64ms, [0,1]: 16ms, [0,0]: 1ms. ※RTC wakeup function only support in CST5041S1.
Reserved	17H	-	xxxx	-	-	-	-	Reserved
DMA0	18H	R/W	xxxx	DMA0.3	DMA0.2	DMA0.1	DMA0.0	DMA0~4, five register built a 20-bits addressing space for read DROM 8-bits data, DMA0 is lowest nibble, DMA4 is highest nibble of DROM address.
DMA1	19H	R/W	xxxx	DMA1.3	DMA1.2	DMA1.1	DMA1.0	
DMA2	1AH	R/W	xxxx	DMA2.3	DMA2.2	DMA2.1	DMA2.0	
DMA3	1BH	R/W	xxxx	DMA3.3	DMA3.2	DMA3.1	DMA3.0	
DMDL	1CH	R/W	xxxx	DMDL.3	DMDL.2	DMDL.1	DMDL.0	Low nibble of DROM data read from this address.
DMDH	1DH	R/W	xxxx	DMDH.3	DMDH.2	DMDH.1	DMDH.0	High nibble of DROM data read from this address. Writing this register means reset watch dog timer if this timer is enabled by option. Write this register with data #Ah will clear RTC counter.
DMA4	1EH	R/W	xxxx	-	-	-	DMA4.0	DMA4 is highest nibble of DROM address.
Reserved	1FH	-	xxxx	-	-	-	-	Reserved

Table 7: All of the Special Function Registers

5.4 Interrupt Vector Address

Vector	Address
RESET	00H
WAKEUP	04H
INT	08H

Table 8: Interrupt Vectors

5.5 Interrupt Controller

There is only one interrupt entry point in this chip. Normally interrupt period is 32768Hz. It can be changed to 65536Hz by option "PWM64K". Program will jump to address 0x008 when an interrupt occurs.

Symbol	Addr	R/W type	Reset	D3	D2	D1	D0	Description
STATUS	00H	R/W	00xx	reserved	PWFG	CF	ZF	Status Register PWFG: PWM interrupt flag. CF: Carry flag. ZF: Zero flag.



CST5022A MASK-type Speech IC

PWM_CTRL	09H	R/W	--x0	reserved	reserved	ENINT	ENPWM	ENPWM: "1" Enable PWM, "0" Disable PWM. ENINT: Enable global interrupt.
----------	-----	-----	------	----------	----------	-------	-------	--

Table 9: SFRs about Interrupt

If the global interrupt enable bit (INTEN) is high and interrupt request (PWFG=1) occurred, then interrupt will be accepted on next clock. On that instant, current (next) program counter, PCDH, MAH and C/Z will be stored in special hardware registers, and program counter will be loaded with entry address of that interrupt. All these are done in one clock. Interrupt enable bit will be cleared too. As long as program enters interrupt service, interrupt enable bit is cleared. It's no need to clear interrupt enable flag in interrupt routine. But hardware will not clear interrupt request flag (PWFG). Software is required to clear it.

When interrupt service routine is done, an RETI shall be executed. This instruction will restore stored program counter, PCDH, MAH and C/Z, will set interrupt enable bit=1 also. (Note that RETI is different from RETS.) Interrupt request can be accepted only when enable bit be set. Note that only one level of INT routine can be used.

5.6 Clock Operation

There are two operation modes in this chip. The state diagram of three MCU operation modes is shown below:

1. NORMAL Mode: In normal mode, system clock oscillator is running, and MCU clock source is come from main oscillator. In NORMAL mode, MCU will go to halt mode after HALT instruction executed.

2. HALT Mode: In HALT mode, the MCU clock stops, users can't change the operation mode when in halt mode. It will go back to NORMAL mode (Program counter=0x004) when I/O wakeup or reset occurred. Please refer to the section of "Halt Mode & Wake up" for the detailed HALT mode description.

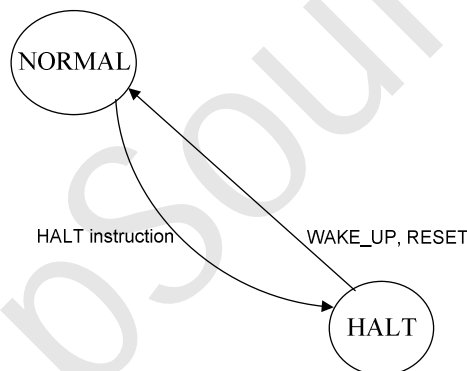

Figure 2: Clock Operation Mode

5.7 Halt Mode & Wake up

The MCU is changed into HALT mode (program counter and system clock stop) when HALT instruction executed. It provides a power saving mode for those applications requiring a very low stand-by current. The PA[3:0], PB[3:0] and PE[3:0] are supporting the wake-up function when rising edge occurred.

The program counter will be 0x004 when HALT instruction executed immediately, then program counter will go to next address after 64 stable clock(system clock) when wake up condition occurred. Reset signal will release HALT state and execute reset procedure because reset is first priority when in HALT mode, so program counter will from 0x004 to 0x000, program counter goes to next address after 64 stable clock cycles. Furthermore, the SRAM will keep their previous data without changing in this mode.



CST5022A MASK-type Speech IC

5.8 Watch Dog Timer Reset (WDT)

The **Watch Dog Timer (WDT)** is used to reset whole chip when detect unexpected execution sequence caused by accident condition, avoiding dead lock of MCU program. WDT will be reset when wake-up from halt, after reset or software clears it. The watch dog timer is a simple counter. It has a fixed length of **256*256*16/system-clock (ex: 0.13 sec for 8.192MHz system clock)** after the clearance of watch dog.

Software must run a "clear watch dog timer" (write to DMDH) instruction before this timer time out when WDT enabled. It will generate a reset signal to reset whole system when WDT over flow. Assembler will check user program about the "reset watch dog" instructions. If more than one "reset watch dog" is found in program, assembler will generate a warning (program code will still be generated). "HALT" instruction will reset watch dog timer. The reset watch dog timer sequence is strongly recommended as:

```
WATCHDOG:
                LD        (1DH), A
```

5.9 Low Voltage Detect (LVD)

The low voltage detect (LVD) function is used to detect whole chip power supply VCC. CST5022A support 16-level LVDS[3:0] to selected detect voltage level, the detected voltage range is from 3.8V to 2.1V.

There have one control register LVDEN used to enable/disable the low voltage detect function. The flag signal LVD_FLAG is used to check the power supply VCC upper or under than low voltage detect level, when VCC upper than LVD level, the flag LVD_FLAG value is low; otherwise, the flag LVD_FLAG value is high when VCC under than VCC.

Symbol	Addr	type	Reset	D3	D2	D1	D0	Description
LVD_CTRL	13H	R/W	0000	-	-	LVD_FLAG (R)	LVDEN	The flag of LVD, '1'=LVD sensing. LVDEN: '1'=Enable LVD function, '0'=Disable LVD function.
LVDS	14H	R/W	0000	LVDS3	LVDS2	LVDS1	LVDS0	LVD level selected, 1111=3.8V, 1110=3.7V, 1101=3.6V, 1100=3.4V, 1011=3.3V, 1010=3.2V, 1001=3.1V, 1000=3.0V, 0111=2.9V, 0110=2.8V, 0101=2.7V, 0100=2.5V, 0011=2.4V, 0010=2.3V, 0001=2.2V, 0000=2.1V.

5.10 8/10/12 Bits PWM/DAC

There are three optional PWM/DAC output resolutions. One is 8-bits output, the sec. is 10-bits output, and the other is 12-bits output. The highest of input data is signed bit: '0' represents positive, '1' represents negative.

CST5022A supports audio output with PWM and DAC two modes. These two modes can be selected by "DACEN" option. If use DAC output mode, option "DACEN" must be enabled. Otherwise, PWM mode is enabled. All PWM registers will be exchanged for DAC mode if "DACEN" option is enabled.

Symbol	Addr	type	Reset	D3	D2	D1	D0	Description
STATUS	00H	R/W	00xx	reserved	PWFG	CF	ZF	Status Register PWFG: PWM interrupt flag. CF: Carry flag. ZF: Zero flag.
AUD_DLL	08H	W	xxxx	AUD_DLL3	AUD_DLL2	AUD_DLL1	AUD_DLL0	The bit1~0 of 10-bits PWM, combine with

AUD_DL[3:0], AUD_DH[3:0] to built 10-bits
PWM if option PWM10 is 1 and PWM12 is 0.
AUD_DLL[3:0]:

5.10.4 Speaker Provided a Wake-up Control Function

Normally, the PWMN and PWMP pin is tied to a speaker for playing music and a sound. This speaker connection structure can be used to wake-up MCU. If PWMWK is enabled, the speaker wake-up function is enabled after go into HALT mode and the PWM function keep operating in normal mode. If speaker wake-up function is enabled, the PWMP pin will be fixed to VSS level and PWMN pin also will be fixed to VSS level by chip. The signal level on PWMN pin will be changed (typically 0mV~10mV) when a sound receives from speaker. The MCU will be waked up if signal level on PWMN pin high enough. The relationship between wake-up signal and PWMN pin is shown in picture below. The wake-up signal goes high if PWMN pin larger than VC level and it goes low if PWMN pin smaller than VC level.

Note:

1. This function consume about 5uA (VDD=5V) typically in HALT mode when “PWMWK” option is enabled.
2. PWM function must be keep silence about 200ms before go into HALT mode. Otherwise, MCU maybe keep in normal mode, not goes into HALT mode.
3. When PWMWK option enabled, PA0 wakeup option must be disabled, please referenced AN-0068_V2.0.

Symbol	Addr	R/W type
--------	------	----------



CST5022A MASK-type Speech IC

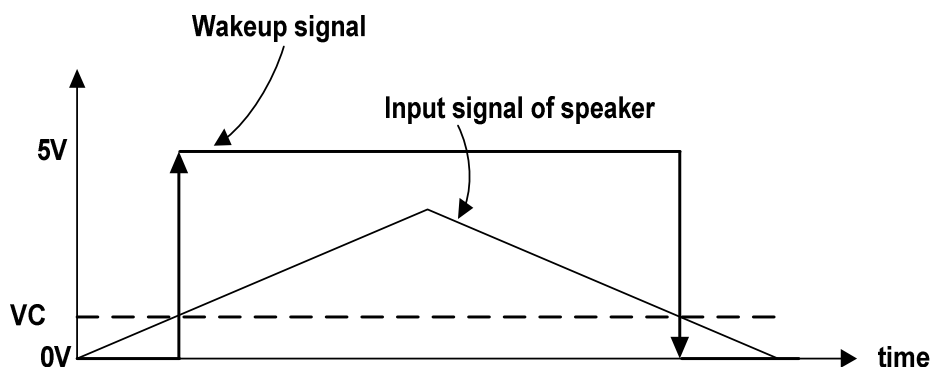

Input signal of speaker vs. Wakeup signal waveform

Figure 4: Speaker wakeup waveform

Notice: Speaker wakeup function, please reference application note “AN-0068_V1.0” on web site.

5.11 Real time clock interrupt (RTC)

RTC function is enabled by RTCEN register. If RTCEN register is enabled, It's will keep running at NORMAL and HALT mode. If MCU is in HALT mode, RTC overflow will wake-up chip and jump to address \$004h.

Notice: RTC wakeup function only support in CST5041S1.

Common I/O of RTC:

RTC	16H	R/W	0000	RTCFG	RTCEN	RTCS1	RTCS0	In HALT mode, RTC can wake up MCU and program will go to wake up vector (\$004h). RTCFG: RTC overflow flag. 0: RTC overflow not occurred. 1: RTC overflow occurred, it can be cleared by software. RTCEN, RTC function enable/disable, '1'=Enable, '0'=Disable. RTCS[1:0], RTC period select. [1,1]: 128ms, [1,0]: 64ms. [0,1]: 16ms , [0,0]: 1ms.
DMDH	1DH	R/W	xxxx	DMDH.3	DMDH.2	DMDH.1	DMDH.0	clear RTC counter.

The RTCFG flag is set every 1m sec ~ 128m sec as below:

RTCS1	RTCS0	RTC Period
0	0	1ms
0	1	16ms
1	0	64ms
1	1	128ms

Table 14. RTCS1,RTCS0: RTC interrupt period selection



CST5022A MASK-type Speech IC

RTC_CFG flag will be cleared by software. This RTC timer can be used in applications that required to wakeup periodically in HALT mode. The RTC clock source is come from LRCOSC oscillator and the frequency is 100KHz. Besides, RTC counter value also support clear function by writing "#Ah" data to register DMDM (\$1DH).

Notice: RTC wakeup time accuracy is about $\pm 50\%$

5.12 Reset Function

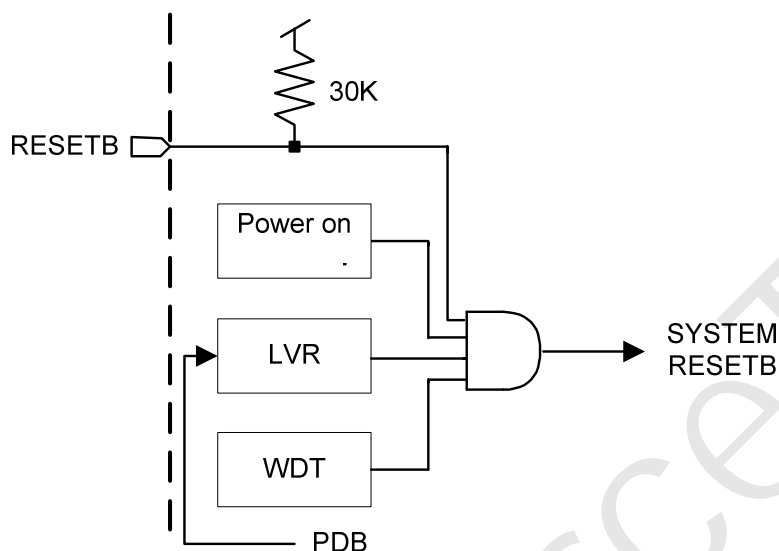

Figure 5: Reset structure

The system reset is come from four signals which are **Power on reset**, **Low voltage reset(LVR)**, **External RESETB pin** and **WDT overflow reset**.

Some reset input pins PB3 and PC3, can be provided to reset this chip according to your option. These pins have 30K Ohm pull up resistor. For normal operation of this chip, a good reset is needed. The operation frequency of MCU will go back to normal mode when reset occurred in HALT mode.

5.13 System Clock Oscillator

This chip MCU is typically operated on 8.192MHz which is generated from internal RC oscillator 32MHz.

5.14 I/O Ports

There are three I/O ports, PA3~PA0, PB3~PB0 and PE3~PE0, whose input/output direction are defined by IOC_PA, IOC_PB and IOC_PCE. PE3~PE0 are input only ports or input/output ports direction defined by IOC_PCE be selected by option. The wake-up functions of PA3~PA0, PB3~PB0 and PE3~PE0 are enabled or disabled by option. All I/O ports provides rising or falling edge wake up function. This double edge wake up function can be enabled by "BIWK" option. Their 1M/50K Ohm pull down resistors are optional.

In order to achieve touch function, CST5022A support 220K Ohm pull down resistors. These resistors can be enabled by using 50K Ohm pull down resistor registers after "PD220K" is enabled. The 220K Ohm resistance value is almost fixed value when VCC change from 2.0V to 5.5V.



CST5022A MASK-type Speech IC

5.14.1 Port PA (input/output)

The Port A is 4-bits bidirectional I/O port. Their directions can be defined by IOC_PA bit by bit. The following table describe the SFRs associated with Port A.

Symbol	Addr	R/W type	Reset	D3	D2	D1	D0	Description
IOC_PA	02H	R/W	0000	IOCA3	IOCA2	IOCA1	IOCA0	"1" = output, "0" = input of related PA bit.
DATA_PA	03H	R/W	xxxx	DPA3	DPA2	DPA1	DPA0	Read from Port A input port and write to output port.

Table 15: SFRs of Ports PA

In output mode, the data can be written out to external pin, and reading this output port will read the data internal latch. Pull-down resistor will be disabled when output mode is selected.

In input mode, Port A and Port B data can be read from external pin, and they are attached with 1M/50K Ohm pull-down resistor or not according to the options.

In addition, each pin of Port A and Port B also can be accompanied with wake-up function according to the options. In HALT mode, if some bits of Port A or Port B are accompanied with wake-up function, any rising edge occurred on that pin will wake up system and turn on oscillator, and the program counter of MCU will jump to the address 0x004. This device will start to execute the wake-up sub-routing.

PA3 is provided with 38KHz modulator

I/O port PA3 built-in a 38KHz modulator combined with register DATA_PA bit-3, this function is enabled by "F38K" option. If F38K option is enabled, I/O port PA3 will output 38KHz clock signal when PA3 is configured as output port and DATA_PA bit-3 = 1. PA3 output low when PA3 is configured as output port and DATA_PA bit-3 = 0.

Notice: The PA3 output pad will be forced to low state automatically by hardware control when in halt mode for avoid external IR LED destroyed. Besides, the F38K option disabled, PA3 is a normal I/O port.

PA0 is provided with an analog input (Schmitt) for wake-up control

PA0 supports an analog input buffer with Schmitt circuit, it is enabled by "RCWK" option and supports low power consumption in halt mode, if PA0 analog signal keep about $0.5 \times VCC$, so this function is suitable for recycle wakeup MCU by external RC time constant, external RC time constant is easy built by VCC connected to R and serial with C to VSS.

The block diagram and electrical characteristic of PA0 analog input buffer shown below. It takes about 5uA when PA0 input signal is 2.5v @VCC=5V in halt mode, otherwise, it takes about 500uA current if RCWK option disabled. This block function is enabled when RCWK option enabled by hardware after power on reset.

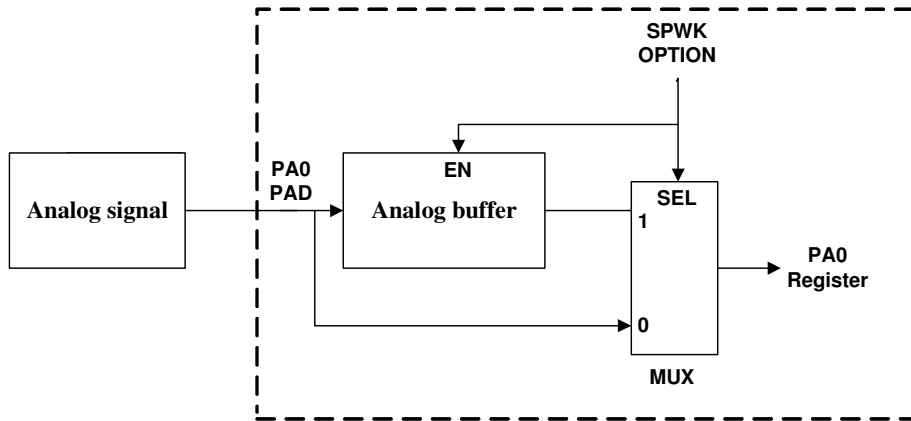
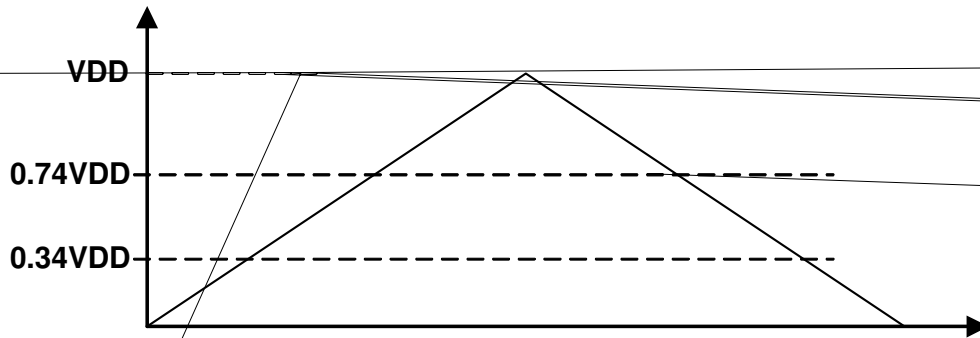

Figure 6. PA0 analog input structure



PA0



CST5022A MASK-type Speech IC

5.14.3 Port PD (input/output)

Whether all 4-bits of the Port D are input or output ports depends on IOC_PD control register. They are accompanied with 1M/50K Ohm pull-down resistor or not according to the options if they are in the input mode.

The following table describe the SFRs associated with Port D.

Symbol	Addr	R/W type	Reset	D3	D2	D1	D0	Description
IOC_PD	0CH	R/W	0000	IOCD3	IOCD2	IOCD1	IOCD0	"1" = output, "0" = input of related PD bit.
DATA_PD	0DH	R/W	xxxx	DPD3	DPD2	DPD1	DPD0	Read from Port D input port and write to output port.

Table 17: SFRs of Port PD

5.14.4 Port PC (output) Selected by option.

The Port C is 4-bits output only port.

The following table describe the SFRs associated with Port C.

Symbol	Addr	R/W type	Reset	D3	D2	D1	D0	Description
DATA_PC	04H	R/W	0000	DPC3	DPC2	DPC1	DPC0	Port C is output port only. Write to Port C output port.

Table 18: SFR of Port PC

5.14.5 Port PE (input) Selected by option.

All 4-bits of the Port E are input ports only. They are accompanied with 1M/50K Ohm pull-down resistor or not according to the options.

The following table describe the SFRs associated with Port E.

Symbol	Addr	R/W type	Reset	D3	D2	D1	D0	Description
DATA_PE	0EH	R/W	xxxx	DPE3	DPE2	DPE1	DPE0	Port E defined as I/O port or input port depends on option PEIO. Read from Port E input port and write to output port.

Table 19: SFR of Port PE

5.14.6 Port PCE (input/output) Selected by option "PCEIO".

Whether all 4-bits of the Port E are input or output ports depends on IOC_PCE control register. They are accompanied with 1M/50K Ohm pull-down resistor or not according to the options if they are in the input mode.

The following table describe the SFRs associated with Port CE.

Symbol	Addr	R/W type	Reset	D3	D2	D1	D0	Description
IOC_PCE	01H	R/W	0000	IOCE3	IOCE2	IOCE1	IOCE0	Enable when option "PEIO" selected. "1" = output, "0" = input of related PE bit.
DATA_PCE	04H	R/W	0000	DPCE3	DPCE2	DPCE1	DPCE0	Port CE is output port only. Write to Port CE output port.

Table 20: SFR of Port PCE



CST5022A MASK-type Speech IC

There are three modes on Port PCE. They are single OP mode, two comparators mode and comparator & OP mode shown in table below.

Item	Port PCE Structure	Relative Options	Reference Figure
Mode 1	Single OP mode	OPEN	Figure 10
Mode 2	Two comparators mode	CMPEN1、CMPEN2、B1RZ、B3RZ	Figure 11
Mode 3	Comparator & OP mode	CMPEN1、OPEN、B1RZ	Figure 12

Table 21: Structure of PCE

These three modes can be enabled by option OPEN, CMPEN1 and CMPEN2. Option B1RZ is used for reading control DATA_PCE1. If B1RZ is enabled, DATA_PCE1 will read always 0. Otherwise, it will read the state of external Port PCE1. Another option B3RZ is the same function as B1RZ. Option B3RZ is used for reading control DATA_PCE3.

Mode1. Single OP mode

Port PCE provides one OP, if option OPEN is enabled. In this mode, the positive, negative input and output pin of OP is configured as below. In order to avoid interference between PCE1 and PCE2 pin, it's recommended PCE1 must be set as input port.

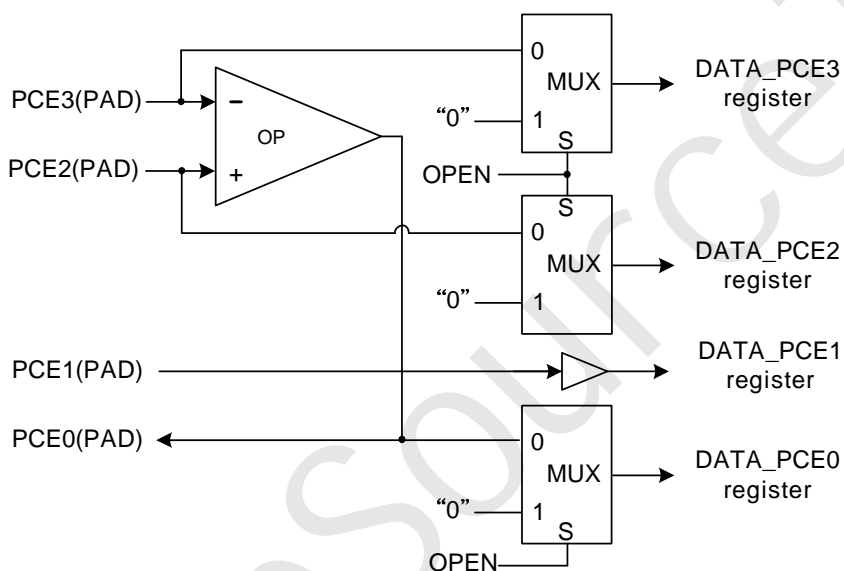

Figure 10. Port PCE mode 1 block diagram

Mode2. Two comparators mode

Port PCE provides two comparators if option CMPEN1

Mode3. Comparator and OP mode

Port PCE provides comparator and OP mode if option CMPEN1 and OPEN are enabled. Option CMPEN2 must be disabled. In this mode, the comparator and OP is configured as below. It's suitable for small signal detect used on remote toy car applications.

Option OPEN, CMPEN1 & B1RZ configuration

OPEN	CMPEN1	CMPEN2	B1RZ	Reading DATA_PCE3~0
0	0	0	x	Port PCE is pure I/O port
1	1	0	0	Reading DATA_PCE2 or DATA_PCE3 register is always 0 Reading DATA_PCE1 register comes from the PE1 external Port Reading DATA_PCE0 register comes from the output of comparator1
1	1	0	1	Reading DATA_PCE2 or DATA_PCE3 register is always 0 Reading DATA_PCE1 register is always 0 Reading DATA_PCE0 register comes from the output of comparator1

Table 24. Port PCE option B1RZ configuration

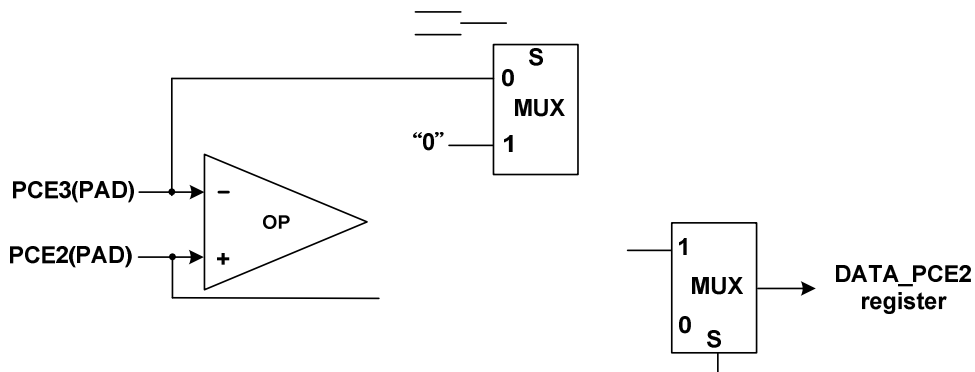

6. CST5022A The Application Circuit

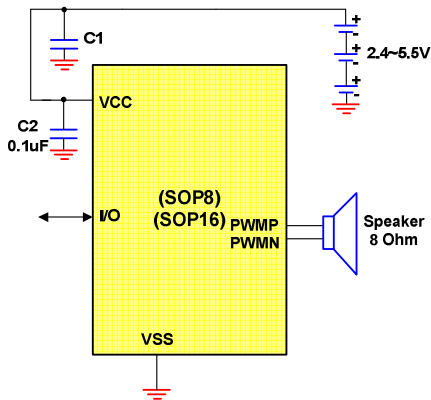

Figure 13. PWM Applications circuit -1

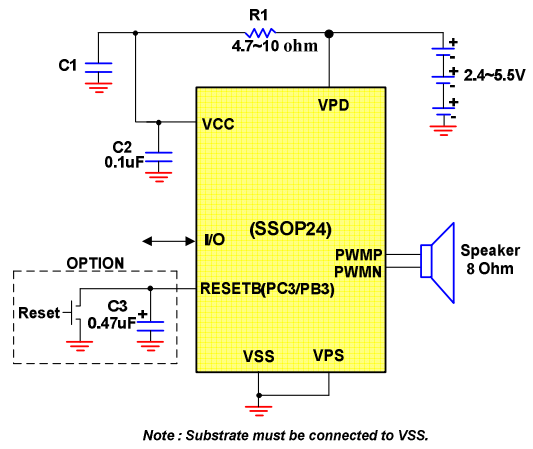
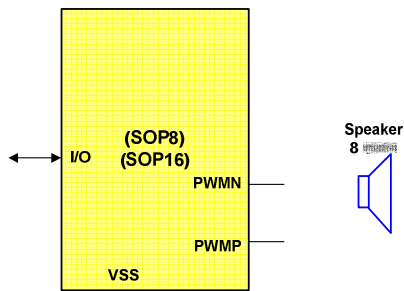

Figure 14. PWM Applications circuit -2

DAC Selected by option





CST5022A MASK-type Speech IC

Notice:

1. Regarding recording or remote car applications, please reference application note on web site.
2. C1 : 47 uF ~ 100 uF(depends on applications), C2 : 0.1 uF
3. DAC Applications circuit not support PWM wakeup function.
4. DAC Applications, please reference application note on web site.

7. CST5022A Option Registers table

Option Name	Function Description
RXEN	Remote function
BZWK	PA0 buzzer trigger wakeup
RCWK	PA0 RC wakeup
PWM64K	PWM int. freq. select
DACEN	DAC function control
WAKEBA	Wake-up enable for PA3~PA0 respectively
WAKEBB	Wake-up enable for PB3~PB0 respectively
WAKEBD	Wake-up enable for PD3~PD0 respectively.
WAKEBE	Wake up enable for PE3~PE0 respectively.
PD50KPA	50K Ohm pull down resistor for PA3~PA0 respectively.
PD50KPB	50K Ohm pull down resistor for PB3~PB0 respectively.
PD50KPD	50K Ohm pull down resistor for PD3~PD0 respectively.
PD50KPE	50K Ohm pull down resistor for PE3~PE0 respectively.
PD1MPA	1M Ohm pull down resistor for PA3~PA0 respectively.
PD1MPB	1M Ohm pull down resistor for PB3~PB0 respectively.
PD1MPD	1M Ohm pull down resistor for PD3~PD0 respectively.
PD1MPE	1M Ohm pull down resistor for PE3~PE0 respectively.
FHC	Force output high of PC3~PC0 respectively.
FHD	Force output high of PD3~PD0 respectively.
RSTBPB3	PB3 external reset pin
RSTBPC3	PC3 external reset pin
WDGENB	Watch dog timer
HALTENB	HALT mode control
OPEN	OPA @ PCE3(in-),PCE2(in+),PCE0(out)
PD220K	Change 50K Ohm pull-down resistor to 220K Ohm
CMP #1	Comparator #1 control
CMP #2	Comparator #2 control
PWM12S	PWM 12 bit select
PWM10S	PWM 10/8 bit select
LOPENC	Output weak low for PC3~PC0
LOPEND	Output weak low for PD3~PD0
OTPLOCK	Security control
F38K	PA3 38KHz output
BIWK	Bi-directional wake up
OPTADJ	OSC IADJ select
PCEIO	Port CE I/O mode control
HDEN	Driving capacity of output port control
PCESEL	Port CE as PC/PE select
B3RZ	PE3 mode select when CMP enable
B1RZ	PE1 mode select when CMP enable



CST5022A MASK-type Speech IC

8. CST5022A The Revision History

Version	Description	Page	Date
1.0	Established		2022-05-30
1.1	Edit "OTP-type" to "MASK-type"		2022-10-11

Table 25: Revision History

ChipSourceTek